

OPERATOR'S MANUAL

RABACONDA



STREET BIKE TIRE CHANGER

EN-US 2022

ADDRESSES

Postal address:

RABAONDA OÜ TIHNIKU 2, PÄRNU 80034 ESTONIA.

Internet address:

<https://rabaonda.com/>

E-mail address for technical support:

support@rabaonda.com

Phone:

(USA) 731-983-5727

(EU) +44 7769 747 494

Our US Distribution Hub:

EAGLE WAREHOUSE & DISTRIBUTION CENTER, INC.823

EAST MAIN ST.HENDERSON, TN 38340

MANUAL INFO

These are the original instructions. The English language is binding. No part of this documentation may be reproduced without the written permission of Rabaonda®.

Table of Contents

1 Preface.....	5
1.1 Identification	5
1.2 Features	5
1.2.1 Significant advantages of the Rabaconda® Street Bike Tire Changer.....	5
2 Warranty Upon Purchase.....	6
3 Introduction.....	6
3.1 Explanation of Documentation	6
3.2 List of Abbreviations.....	7
3.3 Safety Warning Messages in this Manual.....	7
3.4 Intended Users.....	7
3.5 Intended Use.....	8
3.6 Unintended Use	8
3.7 Tools and accessories	8
3.8 What is in the box	9
4 Safety.....	12
4.1 Introduction	12
4.2 Generally Applicable Safety Rules	12
4.3 Personal Protective Equipment	12
4.4 IMPORTANT SAFETY RULES FOR THIS TIRE CHANGER.....	13
4.5 General Safety Rules for Tools.....	13
5 Operation Instructions.....	14
5.1 Warnings and Rules for Safe Operation	14
5.2 Prepare for assembling	14
5.3 Human.....	14
5.4 Operator.....	14
5.5 Workplace	15
5.6 Assembling the tool	15
5.6.1 Assembling Preparation	15
5.6.2 Assembling.....	16
5.7 Prepare for operation.....	17
5.8 Dismount a tire.....	18
5.9 Mount a tire	26
6 Maintenance and repair.....	29
6.1 Preventive Maintenance	29
6.2 Ordering Parts	30

6.3 Packed Transport and Storage.....	31
7 Spare parts and wearing parts.....	32
7.1 Wearing Parts.....	32
7.2 List of Consumables	32
8 Specifications.....	32
9 FAQ.....	33
10 Warranty.....	34
10.1 Warranty Provisions	34
10.2 LIMITED WARRANTY	34
10.3 Liability.....	35

**CHANGE TIRES BY YOURSELF
WHENEVER, WHEREVER NEEDED;
STREET OR TRACK, GARAGE OR PIT!**

1 PREFACE

1.1 Identification

The Rabaconda® Street Bike Tire Changer (Patent Pending) is a nifty, advanced, efficient tire changing tool for street motorcycles. Motorcyclists can easily use it at home, service technicians can use it in workshops or events. The tool allows you to change tires quickly, easily, and efficiently.

In the beginning, it takes some practice to work with it properly. It is a sophisticated tool that requires some experience. Give yourself time to gain this experience by changing a few tires. If you still have problems, contact our Technical Support.

1.2 Features:

- Easy to carry.
- Lightweight, taking very little room in your garage.
- Store it away on a shelf until you need it again.
- Strong carry-bag for comfortable travel and compact storage
- Can be set up within seconds, garage or trackside.
- Innovative frame design with unparalleled stability at low weight.
- Wide leg stance for excellent balance.
- A plastic mounting head reduces the risk of scratching the rim with tire levers.
- Long lever for breaking even the most challenging beads.
- Oval-shaped operating handle with good grip.
- Quickly adapted to different wheel sizes.
- Lifetime Warranty.
- Free shipping in US and EU.
- 6 Months Money Back Guarantee.

1.2.1 Significant advantages of the Rabaconda® Street Bike Tire Changer

- This Tire Changer helps you use your tires strategically; Switch to correct tires for the occasion you're in every time you hit the track.
- Empowers you to change your tires whenever and wherever you need to.
- The tool helps you regain control; no more pestering your mechanic friends for help.
- It saves you a lot of money on dealer tire changes in the long run.
- This tool saves time traveling to the dealership and back (rather spend it riding instead!).
- It allows you to buy whatever tires you want, wherever you get the best price.
- Eliminate busted knuckles and back pain. No 5-gallon buckets come with the territory when trying to change your tires the oldway.
- The tool helps you break the tire bead without damaging or scratching the rims.

2 WARRANTY UPON PURCHASE

(See also Chapter 10).

Lifetime Warranty

Lifetime warranty for manufacturer defects.

Money-back guarantee

All Rabaconda® products have a money-back guarantee if you are unhappy with our tools, no questions asked. You have six months to test and become familiar with our products. Take your time!

3 INTRODUCTION

The Rabaconda® Street Bike Tire Changer is designed for cast, forged and spoked wheels. The tool offers additional rim protection. It is adaptable to any wheel size between 12" - 21" and has excellent ergonomics and low weight. It works on front wheels and on both single-sided and double-sided swingarm rear wheels. With Rabaconda®, you can swap your tires in no time, whether riding the street or hitting the track.

Read this Operator's Manual before operating the Tire Changer



- Pay special attention to safety precautions presented in this manual, as they prevent accidents causing wheel or tool damage or human injury.
- This tool can be dangerous. Therefore, reading this manual and watching tutorial videos on our website before the operation is essential.
- This manual describes characteristics unique to the Rabaconda® Street Bike Tire Changer.
- In this manual, safety is a priority. By reading it, you will become aware of the dangers and hazards of operating this tool.

Using This Manual

This Operator's Manual is created to help familiarize you with Safety, Assembly, Operation, Adjustments, Maintenance and Troubleshooting.

The information contained within this manual was current at the time of printing. Some parts may change slightly to assure you of the best performance. To check for updates, refer to our website or call us to speak to one of our representatives.

3.1 Explanation of Documentation

Chapter 3; 'Introduction' and Chapter 4, 'Safety' is essential for anyone working on the device. For operators is essential:

- Chapter 5; Assembling and Operation Instructions.
- Chapter 8; Maintenance.

3.2 List of Abbreviations

- CE: Conformité Européenne.

3.3 Safety Warning Messages in this Manual

Read this manual carefully before using the Tire Changer to understand how to use it correctly. If there is something in this manual you don't understand, ask Tech support to explain it.

- After reading, store the manual in a safe place, easily accessible for everyone working with the tool.
- Incorrect handling of the equipment could result in personal injury or physical damage.
- The manufacturer assumes no responsibility for any damage caused by mishandling beyond normal usage defined in this Operator's manual.

DANGER!



This symbol indicates a potentially hazardous situation that, if not avoided, could result in death or severe injury, or machine damage.
This ORANGE symbol indicates All WARNING notifications.

WARNING!!



This symbol indicates a potentially and imminently hazardous situation that, if not avoided, will result in death or severe injury.
This RED symbol indicates All DANGER notifications.

CAUTION!



This symbol indicates a potentially hazardous situation that, if not avoided, may result in minor or moderate injury.
This YELLOW symbol indicates All CAUTION notifications.

NOTICE!



This Notice symbol shows special procedures or points out essential facts.

Always adhere to the recommendations and warnings in this manual. They are the recommendations of Rabaconda®. If you ignore these recommendations, there will be no warranty.

3.4 Intended Users

Intended users are technically skilled Motorcycle Drivers or Motorcycle Technicians.

3.5 Intended Use

The Street Bike Tire Changer is intended for use as a tool for removing and installing motorcycle tires.

3.6 Unintended Use

Unintentional use is any other use than described under 'Intended use.'

3.7 Tools and accessories

- Standard Duck Head
- 16" Street Bike Tire Iron
- Plastic protector for 16" Street Bike Tire Iron
- Adaptors for various wheel hub dimensions (single-sided swingarm wheel hubs, etc). Optional.
- Duck head for Cross-Spoked Rims (like on BMW GS, Triumph Scrambler, Triumph Tiger, Moto Guzzi V85, etc.) Optional.
- 15mm Spindle Kit. Optional.
- Drop Center Tools for stiff sidewall tires. Optional.
- Bead Grease Tire Mounting Lubricant (1kg/2.2lbs) Optional.
- Bead Grease Brush. Optional.
- Valve Core Tool. Optional.
- Beadpal Tire Mounting Tool. Optional.
- Tire Changer Shop Mat. Optional.
- Other tools

The list of tools and accessories evolves over time to give customers best possible experience with the Street Bike Tire Changer.

3.8 What is in the box

The tool comes in a cardboard box.

The following parts are in the box. Check the content.



Operator's Manual



Rabaconda Carry bag

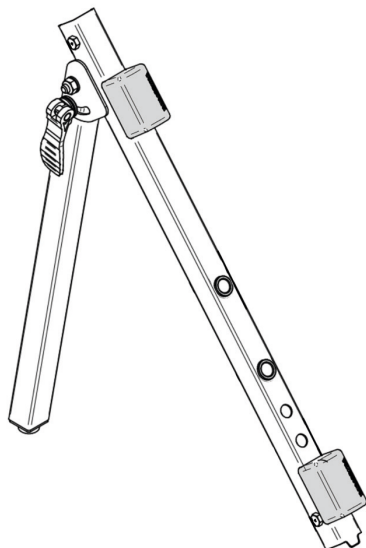

**Main stand with rear leg
and two magnetic wheel support blocks**

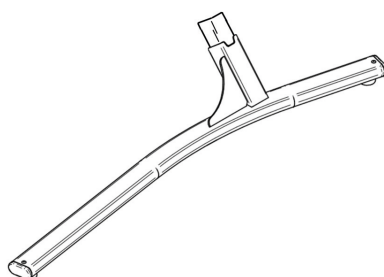

Base leg of the stand

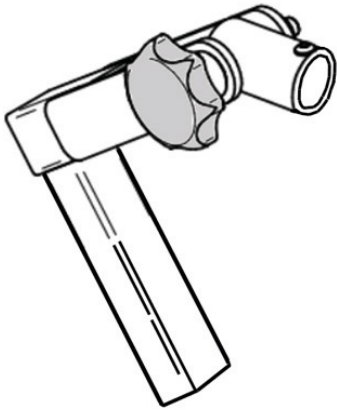

Adjustable bead breaker handle socket (2 settings)

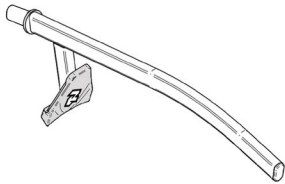

Multi-functional Bead breaker handle with plastic cover.

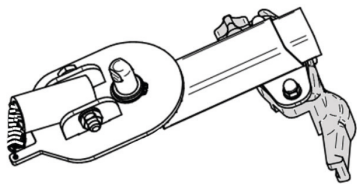

Duck head ratchet system with (dis)mounting head; Duck head

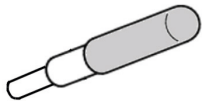

Rim rotation blocker



Tire iron and protective plastic cover

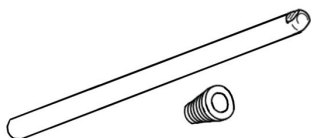

Center spindle and 22-32 mm stepped bushing



Strap for steel wire-spoked wheels.



Quick-release screws, 2pcs

4 SAFETY

WARNINGS!



- READ AND UNDERSTAND ALL SAFETY MEASURES AND WARNINGS BEFORE STARTING ANY OPERATION OR ADJUSTMENTS.
- UNTRAINED PERSONS WHO HAVE NOT THOROUGHLY READ AND UNDERSTOOD THIS MANUAL MIGHT NEVER APPROACH THE DEVICE.
- DO NOT TRY TO USE TIRES WITH A BIB MOUSSE INSERT WITH THIS MACHINE, AS THIS CAN LEAD TO DAMAGING THE TIRE CHANGER.
- USING EXCESSIVE FORCE SHOULD BE AVOIDED AT ALL TIMES AS IT CAN LEAD TO PERSONAL INJURY OR DAMAGE TO THE WHEEL OR THE TIRE CHANGER.

4.1 Introduction

The machine design is such that safe use is possible. Anyone who works with it must know the instructions and regulations stated in this manual.

The owner ensures that users know the instructions, operating regulations, and observations.

4.2 Generally Applicable Safety Rules

This list contains general safety measures which must be complied with for personal safety reasons.

- Make sure children and animals cannot come into the machine's vicinity.
- Only persons who have read and understood the operating instructions might be in the machine's vicinity.
- Unauthorized persons may not perform acts if the machine is in use.
- Do not remove the warning decals, stickers, or markings.
- Always clean the machine properly and keep the workplace free of dirt and obstacles.
- Always ensure sufficient ambient lighting.

4.3 Personal Protective Equipment



While handling, assembling, and maintaining the Tire Changer, adhering to all recommended safety instructions and ensuring that the correct Personal Protective Equipment (PPE) is used.

Always wear:

- Safety gloves; for hand protection and prevention of cuts from sharp edges.
- Steel-tipped safety boots; for foot protection from falling objects.
- Safety glasses for eye protection and prevent damage caused by shooting particles.
- Any other Personal Protection Clothing or Equipment that is required, specified, or dictated by the working environment.
- Your Company can prescribe additional (safety) instructions. This Manual does not describe how to comply with this.

4.4 Important Safety Rules for this Tire Changer

- The operator should be familiar with all functions of the device.
- Persons under 16 should NEVER operate the tool.
- Do not operate the device for any purpose other than what it is meant for. (See warranty for details.)
- Visually inspect the tool; check all fasteners and securing parts.
- Take time to learn proper techniques and never use excessive force to stretch a tire on or off a wheel.
- It takes practice, experience and extra caution to change tires on carbon, custom alloy, or aluminum wheels and high-performance low profile tires. Ensure the mounting/demounting head is not damaged where it makes contact with the rim, as a scratched mounting / demounting head can damage the rim finishing.
- Work behind the tire changer when operating the ratchet system handle, not in front.
- Turn the ratchet socket opening towards you before inserting the handle/lever.
- Take your time to learn the proper technique and allow yourself a few tire changes to master the tool.
- Never use excessive force.
- Always ensure the tire is in the drop center from the opposite side when mounting/ dismounting the tire.
- When changing stiff sidewall tires, warm up the tire before mounting
- Always clean wheels from dirt and debris to avoid scratches on the rim and to the plastic parts of the tire changer.
- If the duck head's inner surface becomes scratched, then the duck head will start damaging the surface on the following rims. Replace the parts if any noticeable damage, that could harm the rim or tire, is detected.

4.5 General Safety Rules for Tools

- Incorrect practice or lack of care can cause wounds, mutilation, suffocation, and other bodily injuries.
- Ensure the work area around the equipment is smooth, clean and free from any obstacles. Keep in mind that a dangerous situation can always arise.
- Always wear safety glasses and protective shoes when carrying out the operation.
- Always use tools that are in a good state of repair. Ensure you know how to use the tools before doing any work.
- ONLY use replacement parts from the same brand as the relevant part.
- Do not use a tool if you are tired or consume alcohol or drugs, affecting your ability to work perfectly.
- Parts that rotate can cause cuts, mutilations or strangulation.

Not Allowed Use

It is not allowed to use the Rabaconda® Tire Changer for other than motorcycle tire changing activities.

5 OPERATION INSTRUCTIONS

5.1 Warnings and Rules for Safe Operation

WARNING!



- Persons under 16 should not operate the Street Bike Tire Changer.
- Ensure you understand all procedures for assembling and operating the Tire Changer.



- Never operate the Street Bike Tire Changer while under the influence of drugs or alcohol.
- **DO NOT** operate the Tire Changer for anything other than what it is meant for.
- During the bead-breaking operation, stay balanced on both feet at any time when using the device, avoid losing your balance and be cautious not to cause any injuries.
- Do not use the stopper pin on wire-spoked wheels as you may damage the spokes. Use the strap.
- Ensure the wheel entirely rests on both wheel support blocks. Otherwise, you will destroy (bend) the center spindle.
- During tire mounting/dismounting, ensure that the tire falls into the drop center from the opposite side of the duck head by using drop center tools or by pushing it down with your hands.
- Always use bead grease when mounting and dismounting a tire.
- After locking the tire iron under the ratchet hook and rotating, hold the tire iron so it does not fall and scratch rims.
- Any excessive force trying to force the tire on or off the rim considerably raises the risk of severe personal injury or damage to the rim, the tire, or the tire changer.

5.2 Prepare for assembling

- Ensure all parts are present.
- Adhere to PPE safety regulations as described in the manual.

5.3 Human

An operator makes the Tire Changer ready for use and starts it as described further in this chapter.

5.4 Operator

Every well-skilled technical person over 16 can act as an operator. For safely using this Street Bike Tire Changer, the operator must have the following specific professional knowledge:

- General knowledge of industrial safety procedures.
- Basic knowledge and skills regarding motorcycle service equipment.
- Basic knowledge and skills regarding motorcycle tire change principles and processes.

5.5 Workplace

To change a tire, you need a minimum distance of 1 m around the device to assemble, remove, and install a tire.

5.6 Assembling the tool

WARNING!



- Read and understand all instructions before assembling the Tire Changer.
- If possible, watch tutorial videos via our website.

5.6.1 Assembling Preparation

- Inspect the whole tool-set visually and check all vital components for damage.
- Check that the working area is relatively smooth and free of obstacles.
- Assemble the tool on a protective floor cover.
- Keep animals far away from the workplace.
- Fit the parts together, as shown in the figure of 5.6.2

5.6.2 Assembling

Fit the parts together, as shown in the figure.

1. Fasten the main stand's rear leg firmly by the quick release cam lever to avoid collapsing during operation.
2. Insert the base leg of the stand to the main stand and fasten with a quick release screw.
3. Screw the center spindle in completely.
4. Attach magnetic wheel supports to the main stand.
5. Attach the L-shaped bead braker handle socket to the main stand and fix with quick release screw.
6. Insert the operating lever fully and properly into the bead braker handle socket.
7. Keep the ratchet system at hand to mount over the center spindle when advancing to corresponding phase.
8. Keep the rim rotation blocking pin at hand for when advancing to corresponding phase.

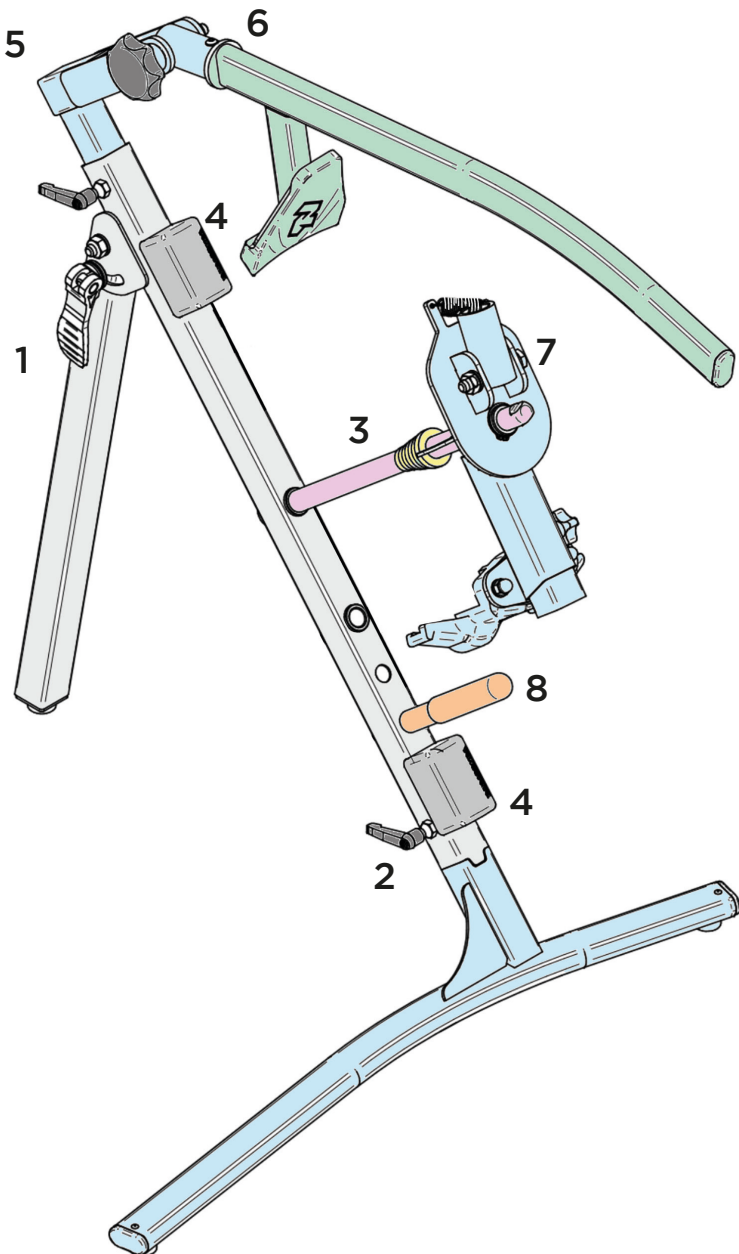

5.7 Prepare for operation

- Clean the wheel from dirt and debris to avoid scratches on the rim and to the plastic parts of the tire changer.
- Inspect the duck head, wheel supports, bead breaker cover, stopper pin, and strap closely for any damage. Replace the parts if any noticeable damage that could harm the rim or tire is detected.
- All parts of the tire changer that will get or might get in contact with the wheel must be clean. Swipe off all dirt and debris.
- Position the wheel supports blocks to match the diameter of the rim to avoid damage to the rim, brake discs, or tire changer.
- Ensure you read this manual thoroughly.
- Use the center spindle and stepped bushing for placing the wheel on the tool frame.
- When changing stiff sidewall tires, ensure to warm them before installing, use plenty of bead grease and more drop center tools.
- Ensure you choose the correct pivot point for the bead breaker handle socket. You can set it for narrow tires (1) or wide tires (2).

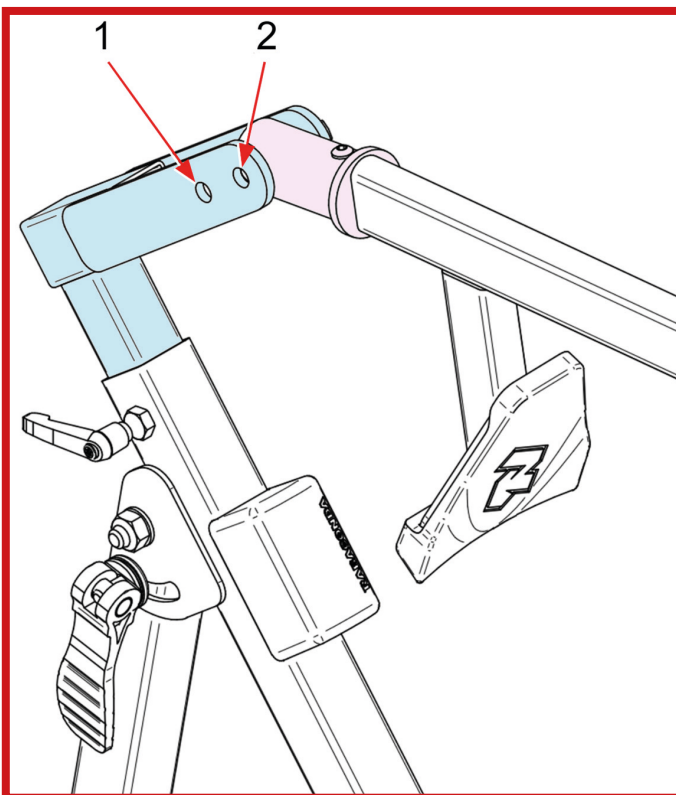

5.8 Dismount a tire

We recommend you also watch the tire change tutorial video.
Scan the code with your phone camera or go to rabaconda.com/start

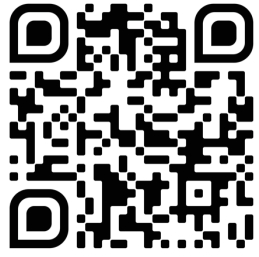

1. Clean the wheel from dirt and debris to avoid scratching the rim and plastic parts of the tire changer.
2. Place the wheel on the tool



- Place the tool on a flat surface.
- Insert the center spindle into the tool.
- Place the wheel on the center spindle.
- Watch the wheel supports blocks. You must adjust them in the next step.

3. Adjust both Wheel support blocks



- To minimize free play, place the stepped bushing or adequate adapter (sold as optional accessories) over the spindle, in the wheel center hub.
- Move the wheel supports blocks in the position to support the wheel from below the rim.

4. Adjust the Bead breaker

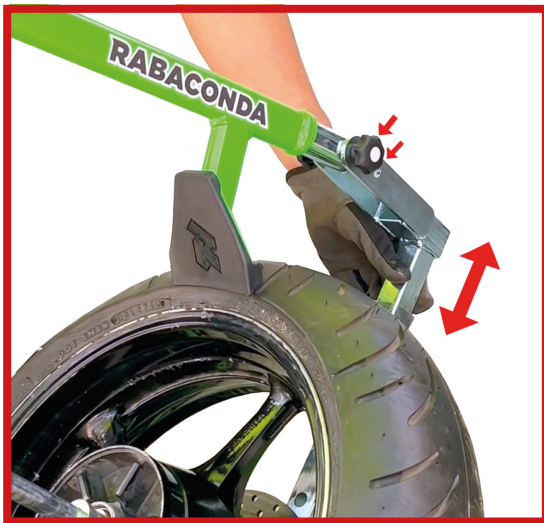

- Please note there are two positions for the bead breaker hinged socket, one for wider and one for narrower rims. Please choose adequate position to have the bead breaker handle at effective working height
- Insert the bead breaker handle.
- Adjust the bead breaker to match the wheel diameter and width.
- Ensure the bead breaker is close to the rim but does not get in contact with the rim.
- Secure the sliding part with the quick-release handle.

5. Break the bead, both sides



- Use the bead breaker to break the bead.
- Turn the wheel by 45° steps and break the bead until the tire is entirely off the rim.
- Turn the bead breaker handle up.
- Flip the wheel.
- Break the bead from the other side.

6. Install the mounting/demounting arm with duck head



- Place the mounting/demounting arm over the center spindle.

7. Position the Duck head



- Fix the duck head position by tightening the knob screw on the mounting/ demounting arm.

NOTICE



Different duck head is needed for cross-spoked rims where spokes run out to the sides of the rim (like on BMW GS, Triumph Scrambler, Triumph Tiger, Moto Guzzi V85, etc.), where the side of the rim is thicker due to spoke placement and standard duck head will not fit. It is sold as optional accessory.

8. Lock dismounting head position



- Fix the duck head position by tightening the knob screw on the mounting/ demounting arm.

9. Turn mounting/demounting arm downwards



- Turn the wheel to have the mounting/demounting arm face downwards, at 6 o'clock position. This is the best starting position.

10. Insert the rim Stopper pin



- Insert the stopper pin into the designated hole on the frame as close to the rim as possible to lock the wheel from rotating.

11 Use of the supplied Strap

NOTICE



Do not use the metal pin and use the strap instead if:

- you cannot install the stopper pin properly due to specific wheel construction (blade-type wheel design, etc)
- the metal pin remains too short due to the wheel's shape.
- brake discs are on both sides, and you cannot install the metal pin.

Important:

- Never use a metal stopper pin with steel spoked wheels.
- The strap should remain behind the rim to prevent Duck head obstruction.



- Position the strap around a spoke as close as possible to the rim, set at 5 o'clock, and on the spoke, which direction is most aligned with the strap direction to avoid damage to the spoke.



WARNING!



Always avoid excessive force as it can damage spokes or the tire changer.

12. Insert the Tire iron and lift the tire over the Duck head



- Apply bead grease on the Duck head and the tire. Always use bead grease when mounting and dismounting a tire.
- Insert the Tire iron between the tire and the forward knob portion of the demount tool.



- Use the bead breaker to push down the tire into the drop center on top, opposite the duck head.
- Simultaneously lift the tire over the Duck head.



- Lock the Tire iron under the hook below the Duck head ratchet system.



- Position ratchet handle socket to face a 9 o'clock position.
- Remove the Bead breaker handle and insert it into the Ratchet socket.
- Stand behind the tire changer before starting to operate the ratchet system.

WARNING!



- Ensure the wheel entirely rests on both wheel support blocks. Otherwise, you will damage (bend) the center spindle.

14. Install the Ratchet handle and operate the tool



- Start pushing the Ratchet system handle up and down to rotate the mounting/ demounting head around the rim.
- Hold the Tire iron with one hand to keep it from falling or making direct contact with the rim
- Rotate the mounting/ demounting head around the rim till first side of the tire is off the rim

15. Remove lower bead from the rim



- Follow a similar process to demount the second bead of the tire.
- At 6 o'clock position, use the tire iron to lift the lower bead over the duck head forward knob portion. Lift the tire for easier tire iron insertion.
- Rotate the mounting/ demounting head around the rim till second side of the tire is off the rim

NOTE:

During the entire dismounting process, ensure that the tire is in the drop center of the rim, opposite the position where the dismounting head works.

5.9 Mount a tire

NOTICE



- ENSURE DURING THE MOUNTING PROCESSES THAT THE TIRE IS IN THE DROP CENTER OF THE RIM FROM OPPOSITE WHERE THE MOUNTING/DEMOUNTING HEAD IS OPERATING.
- Always start by applying plenty of bead grease to the tire bead on both sides.
- Check if the tire has a directional rotation indication and align accordingly on the rim.
- Use multiple drop center tools on stiff sidewall tires to force the tire into the drop center from opposite where the mounting/dismounting head is operating.
- Always warm up a stiff sidewall tire before installing.

1. Mount the first side of the tire



- Remove the bead breaker handle.
- Ensure the duck head is at 12 o'clock position.
- Mount the first side of the tire over the duck head diagonally so that the nose of the duck is visible on top of the bead and the tail of the duck head is under the bead.
- Push the right side of the tire on the rim as much as possible with your hands.
- Fit the breaker handle and operate the ratchet system until the first side of the tire pops on the rim. Stop at 12 o'clock position.

2. Mount the second side of the tire



- Add grease to the second bead.
- Ensure the duck head is in a 12 o'clock position.
- Mount the second side of the tire over the duck head diagonally, so that the nose of the duck is visible on top of the bead and the tail of the duck head is under the bead.

NOTICE



- For stiff sidewall tires use one or two Drop center tools to force the tire into drop center from opposite where the mounting head is operating.
- If you don't have drop center tools, then use either your hands or wooden blocks to push the tire as much as possible to the drop center.

3. Operate ratchet



- Fit the breaker handle and operate the ratchet system until reaching moderate resistance.
- Using your hands, push the top side of the tire as much as possible in the drop center.
- If needed for stiff side wall tires, temporarily use the bead breaker to further force the tire into the drop center.
- Operate the tool till the tire is completely over the rim.
- Remove the handle from the ratchet and fit it in the bead breaker socket.
- If needed, use the bead breaker to help removing the duck head system.

4. Mounting stiff side wall tires using drop center tools



- Mounting stiff sidewall tires requires extra care, patience, caution, and using drop center tools.
- Add some bead grease to the drop center tool and install it at 2 o'clock.
- Operate the ratchet until the 10 o'clock position.



- Apply bead grease on second Drop center tool and place it at 10 o'clock as shown.
- Operate the ratchet while you push the tire into the drop center with your hand as much as possible.
- Operate the ratchet until the tire is completely over the rim.
- Remove the handle from the ratchet and fit it in the bead breaker socket.
- If needed use the bead breaker to help removing the drop center tools and the duck head system.

6 MAINTENANCE AND REPAIR

This manual describes periodic maintenance that the owner can do.

GENERAL WARNINGS FOR MAINTENANCE:



- Always perform maintenance on a level and solid surface in a well-lit, clean and dry area.
- Keep all parts of the tool clean to ensure all parts fit together without problems. Dirty parts lead to damage and poor fitting.
- Provide adequate protection around moving or rotating parts, paying attention to the risk of pinching.
- Only use genuine or equivalent parts.
- Always use proper and good-quality tools.

6.1 Preventive Maintenance

- Regularly clean and lubricate the bead breaker socket and Duck head ratchet system socket.
- Regularly lubricate the thread of the quick-release screws.

6.2 Ordering Parts

Contact Rabaconda® to order spare parts.

When ordering spare parts, you must always have the following information:

- Tool name and Type.
- Part name

1	Main frame
2	Rear leg
3	Base leg
4	Bead breaker bracket
5	Operating lever
6	Center spindle (20mm)
7	Duck head ratchet system
8	Wheel support block
9	Bead breaker plastic cover
10	Duck head (only plastic)
11	Stepped bushing
12a	Blocker pin (including rubber cover)
12b	Rubber cover for blocker pin
13	Ratchet system socket
14	Bead breaker socket
15	Cam lever fastener
16	Quick release screw
17	Duck head knob screw
18	Bead breaker knob screw
19	Rubber leg pad
20	Tube insert
21	Spring
22	Tire iron
23	Tire iron protective plastic cover
24	Strap
25	Carry bag

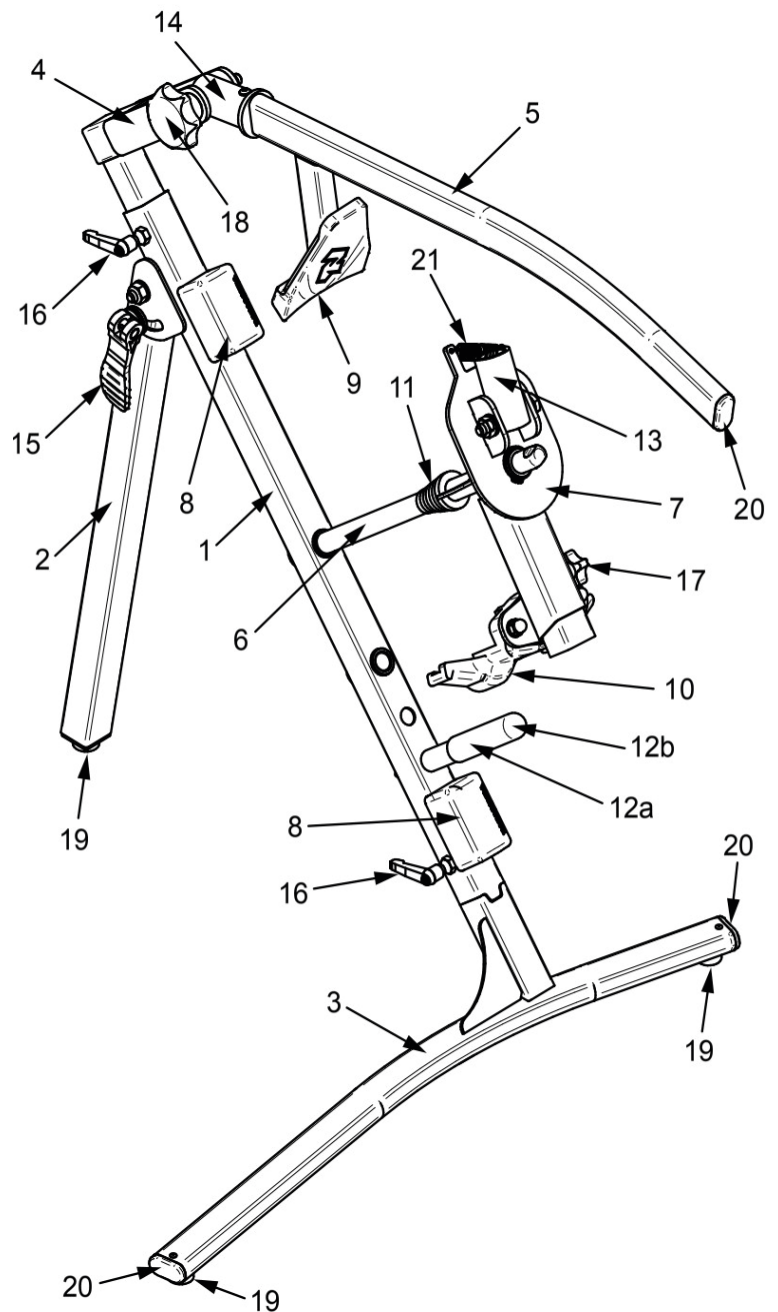

6.3 Packed Transport and Storage

Essential Rules for Transport:

- After use, clean the device from any dirt, bead grease or other stains.
- Disassemble the device and store all parts in the supplied Rabaconda® bag.

Essential Rules for Safe Storage:

- After use, disassemble the device and store all parts in the supplied Rabaconda® bag.
- Pack with care to avoid damage.
- Store the bag in a dry room.
- Avoid strong solvents or abrasives for cleaning.

7 SPARE PARTS AND WEARING PARTS

Always state the correct make, type, and part number when ordering parts.

7.1 Wearing Parts

Wearing parts are parts that usually wear out first.

For the reliable operation of a tool, it is essential that wearing parts are of high quality.

Wear parts are permanently excluded from the warranty.

Wearing parts for the Street Bike Tire Changer:

- Tire iron.
- Plastic cover for the tire iron.
- Plastic Duck head.
- Plastic bead breaker cover.
- Plastic wheel supports.
- Stopper pin cover.
- Strap.
- Carry bag.
- Rubber leg pads.

7.2 List of Consumables

- Bead grease.

8 SPECIFICATIONS

- Suitable for 12 - 21" wheels.
- Wheel hub diameter: 20 - 32 mm.
- Special adaptors for single-sided swing arms and large wheel hubs.
- Weight: 35 lbs (16 kg).
- Materials:
 - Galvanized steel frame;
 - Plastic mounting head, wheel supports, and bead breaker cover.
- Carry-bag dimensions: 29 x 11 x 10 inches (73 x 28 x 26 cm).
- Shipping cardboard box dimensions: 31 x 11.5 x 8 inches (80 x 29 x 21cm).

9 FAQ

Need to remove brake disc/rotor?

- No, you do not need to remove the rotors. The supports below the rim are adjustable, so you can slide them as wide as necessary to accommodate any size brake disc.

Does it balance the wheel?

- No, but a simple table top manual balancer is what track day guys use. Takes a few minutes max per wheel to balance. Rabaconda wheel balancer will become available in a few months time. There are also other handy solutions like balancing beads, Ride-On tire balancing liquid, Centramatic wheel balancers, etc.

What's the minor axle diameter?

- The standard spindle works with 20-32 mm wheel hubs. 15-20 mm center spindle kit is available as an extra accessory.

Does it work on single-side swingarms?

- Yes, we have special adapters available as optional accessories. Our goal is to offer accessories for the tire changer so you can use it for all makes and models of bikes. It is easy with double-sided swing arms - the tire changer comes with a stepped spacer that aligns the wheel on the center spindle. Single-sided swingarm wheels vary between different bike models and need a different approach. We have suitable adapters for most bike types in our range of optional accessories.

Does it work with spoked wheels?

- The Street Bike Tire Changer is designed predominantly for cast wheels, but we have tested it also on spoked wheels with success. In the case of spoked wheels, instead of the metal pin to lock the wheel from spinning, a strap (included with tire changer) through the spokes should be used. Positioned right next to the rim, it holds the wheel from turning as needed when changing a tire. However, proper cautiousness is always required as using excessive force can still damage a spoke.

What about the tire iron?

- After testing out several different shapes and lengths of tire irons, we have found the best one to accompany this tire changer. The box includes the tire iron, so you can just roll up the sleeves. We have even included a protective cover for the tire iron to provide maximum protection for your rims.

What if I don't have a suitable adapter?

- If the free play gets over 4-5 mm between the hub and the adapter, reach out to us, give us the exact dimension of your hub, and we will make a custom adapter for you and ship it out ASAP, and we will add it to our product range.

What if I use very stiff sidewall tires?

- Changing stiff sidewall tires will require more time, patience, extra care, drop center clamps, and skills. Do not use excessive force, and take your time to develop the proper technique.

Can I change dirt bike tires with it?

- There are better ways of self-torture. The rim lock makes changing tires with a duck head a considerable struggle. It is easier with tire irons and a Rabaconda 3-Minute Tire Changer.

Can it be used with mousses inserts?

- No, you can't use a duck head to change tires with bib mousse inserts. Instead, use tire irons and a Rabaconda 3-Minute Tire Changer.

10 WARRANTY

10.1 Warranty Provisions

Rabaconda® guarantees the proper functioning of the provided equipment. However, Rabaconda® is not responsible for unsafe situations, accidents, or damage, which are the result of:

- Ignoring warnings and regulations as stated in this Operator's manual.
- The use of the device for other applications or under other circumstances than stated in this documentation.
- Mutations to the machine include the application of different replacement parts as specified.
- Insufficient or careless maintenance.

10.2 Limited Warranty

This warranty is effective from 15 June 2022 and replaces all previous warranty terms issued by Rabaconda®. All previous warranty terms are null and void.

Lifetime warranty for manufacturer defects. It does not cover wear parts of the product. The duck head, wheel support blocks, bead breaker cover, stopper pin cover, strap, bag, and tire iron with plastic cover are wear parts; the lifetime warranty does not cover them.

Surface finish is not guaranteed as the products are considered tools, and contact points will cause normal wear. Colors, patterns, and finishes are deemed cosmetic only and may vary. Damage of an aesthetic nature such as varnish, enamel, lacquer, paint and damage due to corrosion or the gradual deterioration of the machine is not covered.

Rabaconda® is not responsible for and will not warranty products that show obvious misuse, alteration, or abuse. You agree that Rabaconda® is the sole judge of determinations regarding such misuse, alteration, or abuse.

Warranties on structural steel parts of Rabaconda® products vary depending on the model and date of purchase.

Guarantees apply only to original purchasers and are not transferable. In the case of direct purchase from the factory, the product is automatically registered at the time of sale by the buyer(s). For products purcha-

sed from authorized dealers, the original invoice from that authorized dealer must be presented. Evidence of purchase is required for all warranty claims. Evidence must be in the form of a copy of an original invoice/sales receipt or order confirmation e-mail, showing the date of purchase in the owner's name. Warranties only apply to Rabaconda® products and parts. Third-party products, such as rims, tires, wheels, and spokes, are not covered by the guarantee.

The ratchet system is covered for the life of the original tool, provided there is no evidence of misuse, abuse, alteration, or overloading.

Shipment of products for warranty claims from the customer to Rabaconda® and from Rabaconda® to the customer is the buyer's responsibility.

Rabaconda® reserves the right to revise, amend, modify or withdraw the terms of this warranty policy at any time and for any reason.

Rabaconda reserves the right to determine whether to honor or deny a warranty as it deems appropriate based solely on the objective judgment of Rabaconda® specialists.

10.3 Liability

Rabaconda® can't be held liable for consequential damage (business interruption, product damage, etc.).

**CHANGE TIRES BY YOURSELF WHENEVER,
WHEREVER NEEDED; STREET OR TRACK,
GARAGE OR PIT!**

RABACONDA
COM.

**FOLLOW US
FOR THE LATEST
TIRE CHANGE TIPS**



RABACONDA