



HEATED HAND GRIP KITS

J04259

2016-06-26

GENERAL

Kit Numbers

56047-08A , 56049-08A , 56196-08A , 56512-08A , 56828-08A , 56926-08A , 56100027 , 56100047 , 56100107

Models

For model fitment information, see the P&A retail catalog or the Parts and Accessories section of www.harley-davidson.com (English only).
These kits are not compatible with internally wired handlebars.

Installation Requirements

Unless already installed:

2017-Later Touring Models require separate purchase of an Electrical Connection Harness (Part No. 69201599).

2014-2016 Touring Models require separate purchase of an Electrical Connection Harness (Part No. 69200722).

2016-Later Softail Models require separate purchase of an Electrical Connection Harness (H-D Part No. 72673-11)

WARNING

The rider's safety depends upon the correct installation of this kit. Use the appropriate service manual procedures. If the procedure is not within your capabilities or you do not have the correct tools, have a Harley-Davidson dealer perform the installation. Improper installation of this kit could result in death or serious injury. (00333a)

NOTE

This instruction sheet references service manual information. A service manual for this year/model motorcycle is required for this installation. One is available from a Harley-Davidson dealer.

ELECTRICAL OVERLOAD

NOTICE

It is possible to overload your vehicle's charging system by adding too many electrical accessories. If the combined electrical accessories operating at any one time consume more electrical current than the vehicle's charging system can produce, the electrical consumption can discharge the battery and cause damage to the vehicle's electrical system. See an authorized Harley-Davidson dealer for advice about the amount of current consumed by additional electrical accessories or for necessary wiring changes. (00211c)

WARNING

When installing any electrical accessory, be certain not to exceed the maximum amperage rating of the fuse or circuit breaker protecting the affected circuit being modified. Exceeding the maximum amperage can lead to electrical failures, which could result in death or serious injury. (00310a)

This kit requires up to **2.8 amps** more current from the electrical system.

Kit Contents

Each kit contains one pair of heated hand grips plus connecting parts. See **Figure 8** and **Table 1**.

PREPARATION

WARNING

To prevent accidental vehicle start-up, which could cause death or serious injury, remove main fuse before proceeding. (00251b)

NOTE

- **For vehicles equipped with security siren:** With security fob present, turn ignition switch ON. Disarm security system. **IMMEDIATELY** remove the main fuse per the service manual.
- **For vehicles WITHOUT security siren:** See the service manual to remove the main fuse.

⚠ WARNING

When servicing the fuel system, do not smoke or allow open flame or sparks in the vicinity. Gasoline is extremely flammable and highly explosive, which could result in death or serious injury. (00330a)

1. Remove the fuel tank per the service manual.

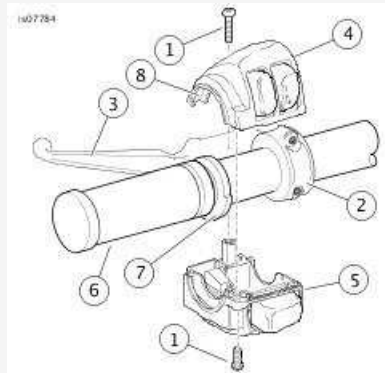

[View interactive image](#)

1.	Screw (2).
2.	Handlebar clamp.
3.	Clutch hand lever assembly.
4.	Upper switch housing.
5.	Lower switch housing.
6.	Left handlebar grip.
7.	Larger diameter of flange.
8.	Grooves.

Figure 1. Left Handlebar Switch Housing (2008-2013 Touring and 2006-Later Softail)

REMOVAL

Left-Side Grip Removal

NOTE

- Cover painted parts to protect finish.
1. Refer to the service manual for specific information on the following generalized steps.
 - a. Refer to **Figure 1** or **Figure 2**. Loosen two screws (1) and the handlebar clamp (2).
 - b. Position the clutch hand lever assembly (3) away from the switch housing.
 - c. Separate the two switch housing sections (4, 5).
 2. **With "glueless" grip:** Remove the grip from the handlebar. **With glued grip:** Remove the grip by carefully cutting it away from the handlebar using a sharp blade or knife.

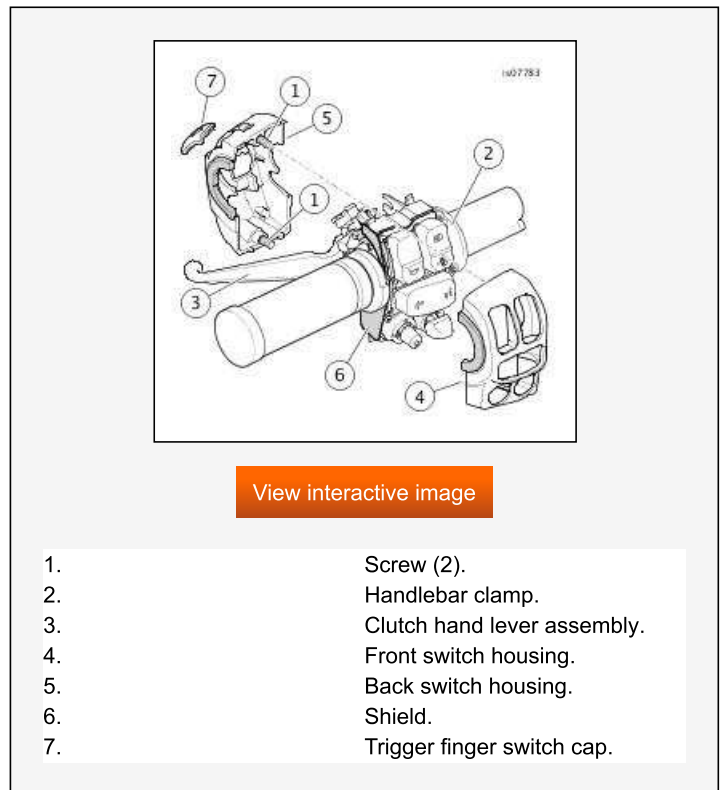

Figure 2. Left Handlebar Switch Housing (2014-Later Touring)

Right-Side Grip Removal

2008-2013 Touring Models:

NOTICE

Do not remove or install the master cylinder assembly without first positioning a 5/32-inch (4 mm) thick insert between the brake lever and lever bracket. Removing or installing the master cylinder assembly without the insert in place may result in damage to the rubber boot and plunger on the front stoplight switch. (00324a)

NOTE

Use the eyelet of a cable strap if the cardboard insert is not available. See [Figure 3](#).

ALL Models:

1. Refer to the service manual for specific information on the following generalized steps.
 - a. Loosen two screws and the handlebar clamp.
 - b. Position the brake lever/master cylinder assembly away from the switch housing.
 - c. Separate the two switch housing sections.
 - d. **2008-2013 Touring Models:** Remove the friction shoe if present.
2. **ALL Models:** Remove the grip from the handlebar.

NOTE

- The twist grip sensor in the right side of the handlebar has a seal cap that protects internal electrodes from dirt and moisture. The seal cap also serves as a retention device for the throttle grip.
- Tug hand grip to remove.
- Upon removing the grip, check the location of the seal cap.

If the seal cap is still fastened to the index pins **inside** the old throttle grip, it can be discarded along with the grip.

If the seal cap is still fastened to **the end of the twist grip sensor**:

- See [Figure 4](#). Insert a small screwdriver or other flat-blade tool into the flat area on one side of the seal cap.
- Press the leg on the underside of the cap to free it from the slot at the end of the twist grip sensor. Pry up one end of the cap.
- Repeat on the other side of the cap.
- Carefully remove the cap and discard it.

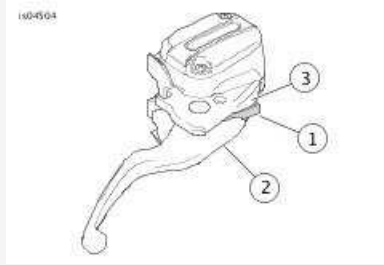

[View interactive image](#)

- | | |
|----|--------------------------------|
| 1. | 5/32-inch (4 mm) thick insert. |
| 2. | Brake lever. |
| 3. | Brake lever bracket. |

Figure 3. Protect Stop Light Switch

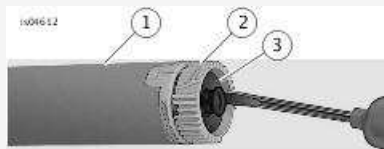

[View interactive image](#)

- | | |
|----|-----------------------------|
| 1. | Handlebar. |
| 2. | Throttle twist grip sensor. |
| 3. | Seal cap. |

Figure 4. Remove Seal Cap

INSTALLATION

NOTE

The throttle grip sensor has two wires, covered in sheathing, coming out of the end that goes into the handlebar. These wires either:

- Have black heat shrink tubing over them, or
 - are terminated with a two-cavity electrical connector.
1. See **TWIST GRIP SENSOR: REMOVAL** in the service manual. Follow the instructions for the specific model vehicle to:
 - a. Access the six-way twist grip sensor jumper harness connector [204] inside the vehicle. Unplug the connector halves.
 - b. Gently pull twist grip sensor out of handlebar only as far as necessary to access black heat shrink tubing or heated grip connector.
 2. See **Figure 8**. Get the left side heated grip (1), long wire harness (15) and short wire harness extension (8) from the kit. Determine if the extension is required for this installation: Does the black pin housing extend past the opposite end of the handlebar? **If YES:** The extension is not needed. It can be discarded. Disconnect the wire harness from the left side grip. **If NO:** Disconnect the wire harness from the left side grip. Connect the pin housing on the extension to the white socket housing on the wire harness. Set the left side grip, and the wire harness or harness assembly aside.
 - a. Temporarily connect the socket housing on the wire harness to the

- b. white pin housing on the end of the left heated hand grip.
- b. Hold the grip and attached wire harness in position along outside of handlebar as if the assembly were installed on the handlebar.
- c. The black pin housing at the end of the wire harness must extend past the **right end** of the handlebar.

NOTE

DO NOT cut any wires leading to the green connector on the twist grip sensor. Cut off the black heat shrink tubing ONLY.

- 3. Locate the black harness coming from the center of the twist grip sensor. Cut the heat shrink or electrical connector from the harness, as close to the connector as possible. Cut away a 25.4 mm (1 in) length of sheathing from the harness. Strip approximately 4 mm (5/32 in) of insulation from the two sensor wires.
- 4. Get the 2-way socket housing (16) and two socket terminals (17) from the kit. Refer to MULTILOCK ELECTRICAL CONNECTORS in the service manual. Follow the instructions to crimp the terminals onto the sensor wires. Get the wire harness set aside in Step 2. Note the wire colors and terminal cavity location in the black pin housing at the end of the wire harness.
 - a. Match the white sensor wire location to the **white striped** black wire location in the black pin housing.
 - b. Match the black sensor wire location to the **solid** black wire location in the black pin housing
 - c. Insert the correct color wire terminal into each cavity of the 2-way socket housing.
- 5. Connect the socket housing on the sensor wires to the black pin housing at the end of the wire harness.

NOTE

Air pressure or an electrical fish tape can be used to thread the wire harness completely through the handlebar.

- 6. Thread the white socket housing and twist grip sensor wire harnesses into the right side of the handlebar.
 - a. While feeding the wiring into the handlebar, gently pull the connector at the end of the twist grip sensor jumper harness to draw the twist grip sensor into the handlebar.
 - b. Thread the left side heated grip wire harness all the way through and out the left side of the handlebar.
 - c. Fit the index tabs on the twist grip sensor into the slots in the handlebar. One index tab and one slot are smaller than the others to prevent improper assembly.

NOTE

- Thoroughly clean handlebar to remove all residual adhesive.

- Remove the protective ring (marked "REMOVE PRIOR TO ASSEMBLY") from the end of the new left side grip.

7. Fasten the white socket housing to the new left side heated hand grip (1).

2008-2013 Touring Models:

1. See **Figure 1**. Position the left side heated grip (6) so the larger diameter portion of the flange (7) is at the bottom. Push the grip fully onto the handlebar.
 - a. Position the lower switch housing beneath the grip. The grooves (8) on the outboard side of the switch housing must fit over the flange on the end of the grip.
 - b. Position the upper switch housing over the handlebar and lower switch housing.
 - c. Start the upper and lower switch housing screws, but do not tighten. Verify that the wire harness conduit runs in the depression at the bottom of the handlebar.
 - d. Position the clutch hand-lever assembly inboard of the switch housing assembly. Engage the tab on the lower switch housing in the groove at the bottom of the clutch lever bracket.
 - e. Align the hole in the handlebar clamp with the hole in the clutch lever bracket. Start the lower screw with flat washer. Adjust the switch housing and clutch hand control position for rider comfort.
 - f. Tighten first the upper, then the lower handlebar clamp screws to 6.8–9 N·m (60–80 **in-lbs**).
 - g. Tighten first the lower, then the upper switch housing screws to 4–5.4 N·m (35–45 **in-lbs**).

2008-2013 Touring Models:

2. See **Figure 5**. Locate the B+ (battery positive) connector (1) on the main electrical harness under the seat (a red wire with an unused gray connector). Remove the cover (2) from the connector.
3. See **Figure 8**. Plug the adapter harness (11) from the kit into the B+ connector.
4. Cut the heated hand grip harness red wire to within easy reach of the end of the adapter harness red wire. Use a sealed splice connector (4) from the kit to splice the two wires per the service manual.

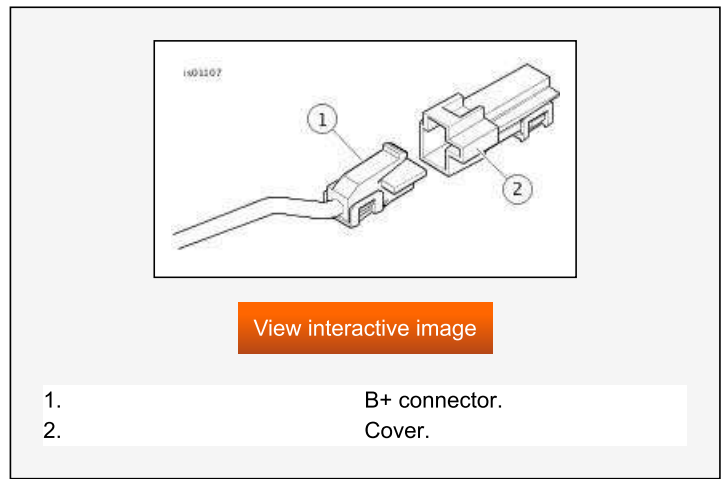

Figure 5. B+ Connector

5. Get the orange/white fuse block adapter wire (10) from the kit. Note the terminal on each end (see Figure 6. Only the terminal **WITHOUT the spring tabs** fits into the fuse cavity. Carefully cut the terminal **WITH** spring tabs from the wire and discard it.

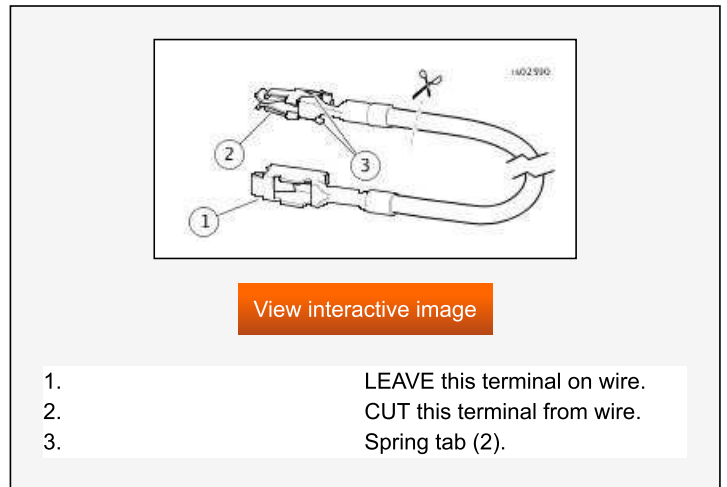

Figure 6. Fuse Block Adapter Wire

6. Locate the fuse cavity indicated as "P&A IGN" "2A MAX". There is a bus bar feeding one side of this circuit, but no mating wire or fuse is present. Remove the three existing fuses in this row, noting their location.
7. Gently remove the orange plastic secondary lock from the fuse block. Insert the terminal on the orange/white adapter wire until it stops. Refer to a nearby factory-installed terminal for comparison to verify proper orientation and depth. Install the secondary lock.
8. Cut excess length from the orange/white wire on the heated hand grip to within easy reach of the orange/white adapter wire installed in Step 8.

⚠ WARNING

Be sure to follow manufacturer's instructions when using the UltraTorch UT-100 or any other radiant heating device. Failure to follow manufacturer's instructions can cause a fire, which could result in death or serious injury. (00335a)

- Avoid directing heat toward any fuel system component. Extreme heat can cause fuel ignition/explosion resulting in death or serious injury.
- Avoid directing heat toward any electrical system component other than the connectors on which heat shrink work is being performed.
- Always keep hands away from tool tip area and heat shrink attachment.

9. Get the **blue** sealed splice connector (4) from the kit. Splice the orange/white wire from the heated hand grip power harness to the orange/white adapter wire per the service manual.
10. See [Figure 8](#). Install a 2A fuse (13) from the kit into the P&A IGN fuse cavity to complete the circuit. Install the three fuses removed in Step 2 into the proper cavities.
11. Install the dust cover onto the fuse block. Install the fuse block. Install the main fuse holder per the service manual.
12. Open the cover of the fuse holder on the heated hand grip power harness. Plug the remaining 5A fuse (14) from the kit into the fuse holder. Close the cover.
13. Check along the entire length of the wiring for rubbing, chafing or pinch points.

14. Fasten the black wire with ring terminal to any ground stud on the frame. Proceed to **COMPLETION**.

2014-2016 Touring Models:

1. See **Figure 2**. Verify that the shield (6) is in correct position on the outboard side of the switch module.
 - a. Install the switch housing sections (4, 5) onto the switch module. Tighten captive screws (1) until snug.
 - b. Install clutch control lever assembly (3).
 - c. Install handlebar clamp (2) with two screws removed earlier, but do not tighten. Position clutch control lever assembly and switch housing for rider comfort. Tighten hand control clamp screws to 8.1–12.2 N·m (72–108 **in-lbs**).
 - d. Tighten switch housing screws to 4–5 N·m (35–45 **in-lbs**).
 - e. Slide trigger finger switch cap (7) right to install.

NOTICE

Do not route the handgrip main harness inside the switch housing. Wires routed inside the switch housing could result in short circuits and equipment damage. (00369a)

2. Route the heated hand grip main wire harness between the hand grip and left switch housing, then under the switch housing.
3. See **Figure 8**. Are there holes on the left underside of the handlebar? **If YES:** Install wire retainer clips (12) from the kit in the holes. Fasten the wire harness to the clips. **If NO:** Use cable straps (9) to fasten the wire harness to the handlebar.
4. Obtain the **new** right side heated throttle grip (2) from the kit. Insert a screwdriver or other flat-blade tool between the body of the throttle grip and the end cap. Carefully pry the end cap off the grip.

NOTE

In the next step, DO NOT pull the plug from the throttle grip by grasping the wires or terminal pins. Only grasp the rubber tab on the plug.

5. Tucked inside the outboard end of the throttle grip is a round rubber plug, with orange and green wires on one side, and two pin terminals on the other. Using a needle-nose pliers or similar tool, carefully grasp the rubber tab on the wire side of the plug. Pull the plug out from the grip through the outboard opening.

NOTE

Thoroughly clean handlebar and inside of throttle grip to remove all dirt.

6. Slide the **new** heated throttle grip over the end of the handlebar. Rotate the grip to verify that the internal splines are engaged with the external splines on the twist grip sensor.

NOTE

- If handlebar grips are patterned, align pattern on right grip with pattern on left grip with throttle in fully closed position.
- Do not pull the switch housing so far inboard as to cause the throttle grip to bind or drag on the handlebar. Actuate the throttle grip to verify that it freely returns to the idle position.

7. Refer to **Figure 1** or **Figure 2**, which show the similar left side housing installation. Install the right side handlebar controls in the same way.

WARNING

Before starting engine, be sure throttle control will snap back to idle position when released. A throttle control that prevents engine from automatically returning to idle can lead to loss of control, which could result in death or serious injury. (00390a)

8. Verify that the right grip/throttle sleeve rotates and returns freely. The sleeve must not bind on the handlebar or switch housing.

NOTE

The terminal sockets on the twist grip sensor are offset to one side. The pins can only be inserted one way.

9. Using a needle-nose pliers or similar tool, carefully grasp the tab on the wire side of the round rubber plug at the outboard end of the throttle grip.
 - a. Insert the plug back through the opening in the grip. Insert the terminal pins into the sockets at the end of the twist grip sensor.
 - b. Press the rubber plug firmly to verify that the pins are fully seated in the sockets.
10. Install the chrome end cap onto the end of the throttle grip.

Connection to Vehicle Wiring

1. Follow existing wiring to route the heated hand grip main wire harness from the left side grip:
 - a. through, across or around the fork bracket,
 - b. along the vehicle frame,
 - c. to a general location under the seat
2. See [Figure 8](#). Use cable straps (9) from the kit to fasten the hand grip wiring to wire harnesses along the vehicle frame. **2014-Later Models:** Continue after Step 15.

2014-Later Touring Models

NOTE

Unless already installed, an Electrical Connection Harness (Part No. 69200722 for 2014-2016 Models or 69201599 for 2017 and Later Models, available separately) must be installed per the instructions in **that** kit.

1. Follow instructions in the Electrical Connection Harness Kit to:
 - a. Splice the **orange/white** wire in the hand grip kit to the **violet/blue** wire on the Electrical Connection Harness.
 - b. Splice the **red** wire in the hand grip kit to the **red/blue** wire on the Electrical Connection Harness.
 - c. Splice the **black** wire in the hand grip kit to the **black** wire on the Electrical Connection Harness.
 - d. Install cap into 4-way pin side of connector if not used.
 - e. Heat-shrink the sealed splices.
 - f. Fasten the black wire with ring terminal to any ground stud on the frame. Proceed to **COMPLETION**.

2016-Later Softail Models

NOTE

Requires separate purchase of an Electrical Connection Harness (H-D Part No. 72673-11).

1. Locate the Digital Technician connector [91A] (a gray six-way Deutsch pin connector with a rubber boot) under the seat. Place the Electrical Connection Harness at connector [91A], but DO NOT connect now.
2. Route the heated hand grip wires over to the Electrical Connection Harness. DO NOT cut off the in-line fuse holder on the red wire, but cut the wires to a suitable length to easily reach the sealed splice connectors on the Electrical Connection Harness.
3. Splice the black hand grip wire to the **black** wires in the Electrical Connection Harness.
4. Splice the orange/white hand grip wire to the **red/yellow** wires in the

Electrical Connection Harness.

5. Splice the red hand grip wire to the **red/blue** wires in the Electrical Connection Harness.
6. Use a heat gun or suitable radiant-heating device to shrink the connector to the wires.
7. Pull the rubber boot out from the gray Digital Technician pin connector [91A]. Cut the boot off the wires.
8. Connect the socket housing of the Electrical Connection Harness to connector [91A].
9. Insert the rubber boot into the open pin connector of the Electrical Connection Harness.
10. Loosen or remove the four screws holding the ECM to the mounting bracket. Route the Electrical Connection Harness under the ECM connector. Tighten the four screws to 5.1–6.2 N·m (45–55 **in-lbs**).
11. Heat-shrink the sealed splices.
12. Fasten the black wire with ring terminal to any ground stud on the frame. Proceed to **COMPLETION**.

COMPLETION

NOTE

DO NOT perform the following steps until the heated hand grips and all related wiring have been installed per this instruction sheet.

1. Verify that the right grip/throttle sleeve rotates and returns freely. The sleeve must not bind on the handlebar or switch housing. DO NOT operate the vehicle unless the throttle functions properly.
2. Verify handlebar rotates freely and fully from right to left without pulling on the wires.

NOTE

To prevent possible damage to the sound system, verify that the ignition switch is OFF **before** installing the main fuse.

1. Verify that the ignition switch is OFF. See the service manual to install the main fuse.
2. Install the fuel tank per the service manual. Install any other vehicle components removed earlier per service manual or kit instructions.

⚠ WARNING

After installing seat, pull upward on seat to be sure it is locked in position. While riding, a loose seat can shift causing loss of control, which could result in death or serious injury. (00070b)

3. See the service manual to install the seat.

NOTE

- To prevent battery drain, these heated hand grips are designed to function only with the engine running. The hand grips produce peak heat with the engine running at cruising speed.
 - The heat settings on the heated hand grip control dial range from 1 (minimum) to 6 (maximum).
4. Before starting the vehicle, check that the hand grips are not producing heat.
 5. Start the engine. Check the hand grips at all settings for proper heating.

Troubleshooting

See **Figure 7** for the heated hand grip schematic diagram.

Hand Grips Do Not Produce Heat

1. See **Figure 1**. Check for proper wire routing. The hand grip main harness must be routed outside of the switch housing. If the wires were routed internally, disassemble the left handlebar switch housing and

inspect for pinched wires. If wires are pinched, replace the left side hand grip and repeat the installation process with the correct wire routing.

2. Check the wire connections of the orange/white, red and black hand grip main wire harness wires.
 - a. If a connection is damaged, loose or weak, repair the connection. Test the hand grips.
 - b. If all connections are good, continue with the next step.
3. Remove the left grip from the handlebar.
4. Disconnect the connector on the left grip from the right grip wire harness.
5. Check continuity across the two connectors in the left grip. If the test shows continuity, the hand grips are functional.
6. Remove the seat according to service manual instructions.
7. Start the vehicle.
8. Check for 12 VDC across the red and black wires of the hand grip main wire harness.
 - a. If 12 VDC is not present across the wires, check the fuse (14) in the wire harness and replace it if blown.
 - b. If 12 VDC is not present, replace the left grip and wire harness and test the hand grips.

Hand Grips Produce Heat with Ignition (Key) Switch Off

If the hand grips produce heat with the ignition switch off, then either the hand grips are incorrectly wired to the vehicle, or the left side grip and wire harness are faulty.

Carefully check all heated hand grip wire connections on the vehicle. If the connections are correct, replace the heated hand grip main wire harness, then test the hand grips.

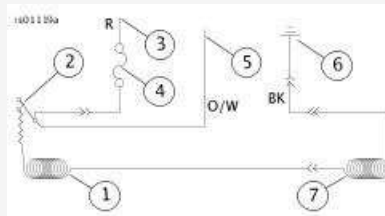

[View interactive image](#)

- | | |
|----|--|
| 1. | Left hand grip. |
| 2. | Heat control. |
| 3. | Positive to main circuit breaker or battery + connector. |
| 4. | Fuse. |
| 5. | Positive to accessory power. |
| 6. | Negative ground. |
| 7. | Right hand grip. |

Figure 7. Heated Hand Grip Schematic

SERVICE PARTS

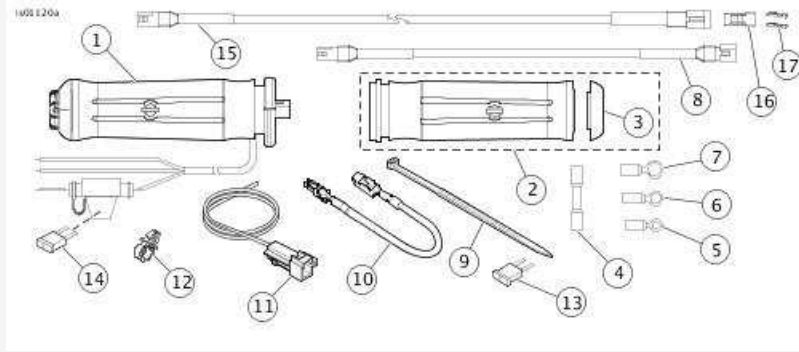

[View interactive image](#)

Figure 8. Service Parts, Heated Hand Grip Kits

SERVICE PARTS

Table 1. Service Parts

KIT	ITEM	DESCRIPTION (QUANTITY)	PART NUMBER
Kit 56047-08A Flame Heated Grips	1	Left-side heated grip	56100-04B
	2	Right-side heated throttle grip (includes Item 3)	56048-08
	3	■ End cap, right-side grip	55940-08
Kit 56049-08A Ironside Heated Grips	1	Left-side heated grip	Not Sold
	2	Right-side heated throttle grip (includes Item 3)	Not Sold
	3	■ End cap, right-side grip	Not Sold
Kit 56196-08A Chrome and Rubber (Small Diameter) Heated Grips	1	Left-side heated grip	56617-04B
	2	Right-side heated throttle grip (includes Item 3)	56615-08
	3	■ End cap, right-side grip	55950-08
Kit 56512-08A Contoured Chrome and Rubber Heated Grips	1	Left-side heated grip	56514-04B
	2	Right-side heated throttle grip (includes Item 3)	56513-08
	3	■ End cap, right-side grip	55949-08
Kit 56828-08A Aileron Heated Grips	1	Left-side heated grip	Not Sold
	2	Right-side heated throttle grip (includes Item 3)	Not Sold
	3	■ End cap, right-side grip	Not Sold
Kit 56926-08A Skull Collection Heated Grips	1	Left-side heated grip	56927-05A
	2	Right-side heated throttle grip (includes Item 3)	56928-08
	3	■ End cap, right-side grip	55957-08
Kit 56100027 Slipstream Collection Heated Grips	1	Left-side heated grip	56100038
	2	Right-side heated throttle grip	56100032
	3	■ End cap, right-side grip	56100024

KIT	ITEM	DESCRIPTION (QUANTITY)	PART NUMBER
Kit 56100047 Streamliner Collection Heated Grips	1	Left-side heated grip	56100049
	2	Right-side heated throttle grip	56100050
Kit 56100107 Airflow Collection Heated Grips	1	Left-side heated grip	56100109
	2	Right-side heated throttle grip	56100096
Items common to ALL Kits	4	Sealed splice connector (2)	70586-93
	5	Ring terminal, #10 (2)	9857
	6	Ring terminal, 1/4 inch (2)	9858
	7	Ring terminal, 5/16 inch	9859
	8	Wire harness, extension, 10.5 inches (267 mm) long	70259-02
	9	Cable strap, black, 7.75 inches (197 mm) long	10006
	10	Wire, fuse block adapter	70329-04
	11	Wire harness, adapter	70310-04
	12	Clip, wire retainer (4)	70345-84
	13	Fuse, "mini" blade type, 2 Amp (gray) (for vehicle fuse block)	54305-98
	14	Fuse, "mini" blade type, 5 Amp (light tan) (for inline fuse holder) (NOTE: A 4 Amp fuse is permissible in this position)	72331-95
	15	Wire harness, 30 inches (0.76 M) long	70282-08
	16	Socket housing, 2-way (black)	72912-01BK
	17	Socket terminal (2)	72991-01