



INSTRUCTIONS

-J06602

2017-08-23

HEADLAMP SHELL

GENERAL

Kit Number

67700455

Models

For model fitment information, please see the P&A Retail Catalog or the Parts and Accessories section of www.harley-davidson.com (English only).

Installation Requirements

▲ WARNING

The rider's safety depends upon the correct installation of this kit. Use the appropriate service manual procedures. If the procedure is not within your capabilities or you do not have the correct tools, have a Harley-Davidson dealer perform the installation. Improper installation of this kit could result in death or serious injury. (00333a)

Visit <https://serviceinfo.harley-davidson.com> for the latest instruction sheet.

These items are available at your local Harley-Davidson dealership.

- Separate purchase of Headlamp Kit 67700355 or Kit 67700356 is required for this installation.
- **2016-2017 XL1200CX models:** Separate purchase of Mounting Block (Part No. 67746-11) is required for this installation.
- **2010-2017 XL1200X models:** Separate purchase of Mounting Block (Part No. 67746-11) is required for this installation.

Kit Contents

See Figure 3 and Table 1.

REMOVAL

1. Remove windshield (if equipped).

NOTE

Before disconnecting battery, fuel pressure must be relieved from the fuel lines of the EFI system. Refer to the applicable service manual for instructions.

2. Remove seat, if necessary. See service manual.

▲ WARNING

To prevent spray of fuel, purge system of high-pressure fuel before supply line is disconnected. Gasoline is extremely flammable and highly explosive, which could result in death or serious injury. (00275a)

▲ WARNING

Stop the engine when refueling or servicing the fuel system. Do not smoke or allow open flame or sparks near gasoline. Gasoline is extremely flammable and highly explosive, which could result in death or serious injury. (00002a)

3. Remove fuel tank if necessary. See service manual.

▲ WARNING

To prevent accidental vehicle start-up, which could cause death or serious injury, disconnect negative (-) battery cable before proceeding. (00048a)

▲ WARNING

Disconnect negative (-) battery cable first. If positive (+) cable should contact ground with negative (-) cable connected, the resulting sparks can cause a battery explosion, which could result in death or serious injury. (00049a)

4. Disconnect battery cables, negative (-) cable first.

Headlamp Removal

NOTE

1200C: If vehicle has Mounting Block (67746-11) already installed, do not remove it.

1. Disconnect headlamp connector from vehicle harness.

NOTE

Record the location of the wires in the connector before removing.

2. Remove headlamp connector from headlamp wire harness.
3. Remove screw, lockwasher, and headlamp shell assembly.

-J06602

Many Harley-Davidson® Parts & Accessories are made of plastics and metals which can be recycled. Please dispose of materials responsibly.

1 / 4

INSTALLATION

Wiring Harness and Headlamp Mounting Block Assembly

NOTE

Use caution during installation, to prevent scratching the headlamp shell, mount and mounting block.

Vehicles with Mounting Block (67746-11) do not remove mounting block, it will be used when installing bucket and headlamp kits.

NOTE

2016-2017 XL1200CX: Require mounting Block 67746-11.

2010-2017 XL1200X: Require mounting Block 67746-11.

2010-2017 1200C: Use OE mounting block.

NOTE

If you purchased mounting block (67746-11) use original 3/8-16 in screw that was removed from original mounting block. Do not use the 5/16 in screws from kit, these screws will not fit properly.

1. See Figure 1. Install mounting block (1) to triple clamp (2) using one of the two 5/16 in. screws (4) from the kit and washer (3).

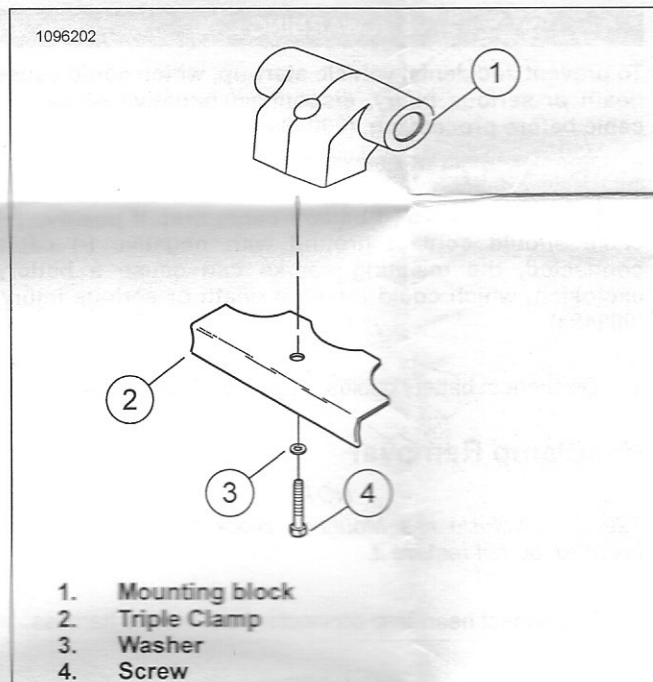

Figure 1. Mounting Block to Triple Clamp (Typical)

2. Assembly headlamp (A or B) to bracket isolator (2) using four screws (12) and four washers (13). Tighten.

Torque: 11.5–14.9 N·m (8.5–11.0 ft·lbs)

3. See Refer to Figure 3. Assemble headlamp spacer (14) to headlamp bucket (1).
4. Connect harness on inside of bucket to headlamp.
5. Assembly headlamp (A or B) and bracket isolator (2) through spacer (14) and into bucket assembly (1).
6. Assembly bucket bezel (15) with screw (6) and hex nut (10) to tighten bezel ring to clamp headlamp into bucket assembly (1). Tighten.

Torque: 1–1.5 N·m (9–13 in·lbs)

NOTE

If assembly requires additional washers for spacing, these have been included in the kit.

7. Mount completed bucket/headlamp assembly to mounting block (16) with screw (7) and two washers (8).
8. See Figure 2 Connect harness (2) to connector (1) on back of bucket assembly and OE harness (3).

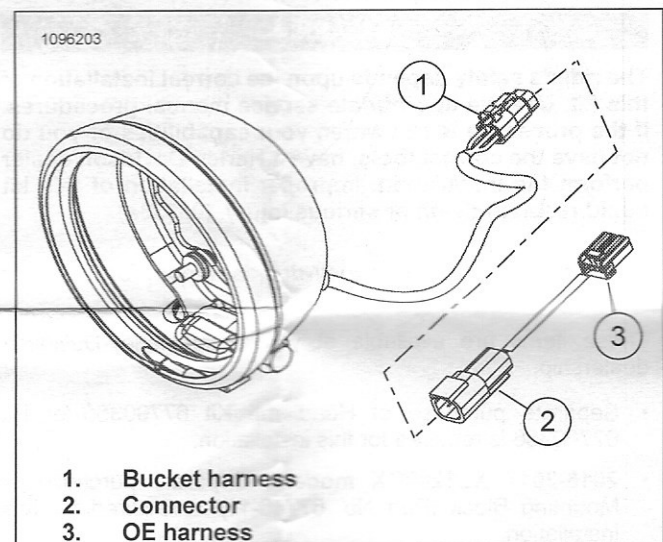

Figure 2. Harness Connection

9. If removed, install fuel tank. See service manual.
10. If removed, install seat. After installing seat, pull up on the seat to verify that it is secure. See service manual.
11. Adjust headlamp. See service manual.
12. If applicable, install windshield.

SERVICE PARTS

1096201

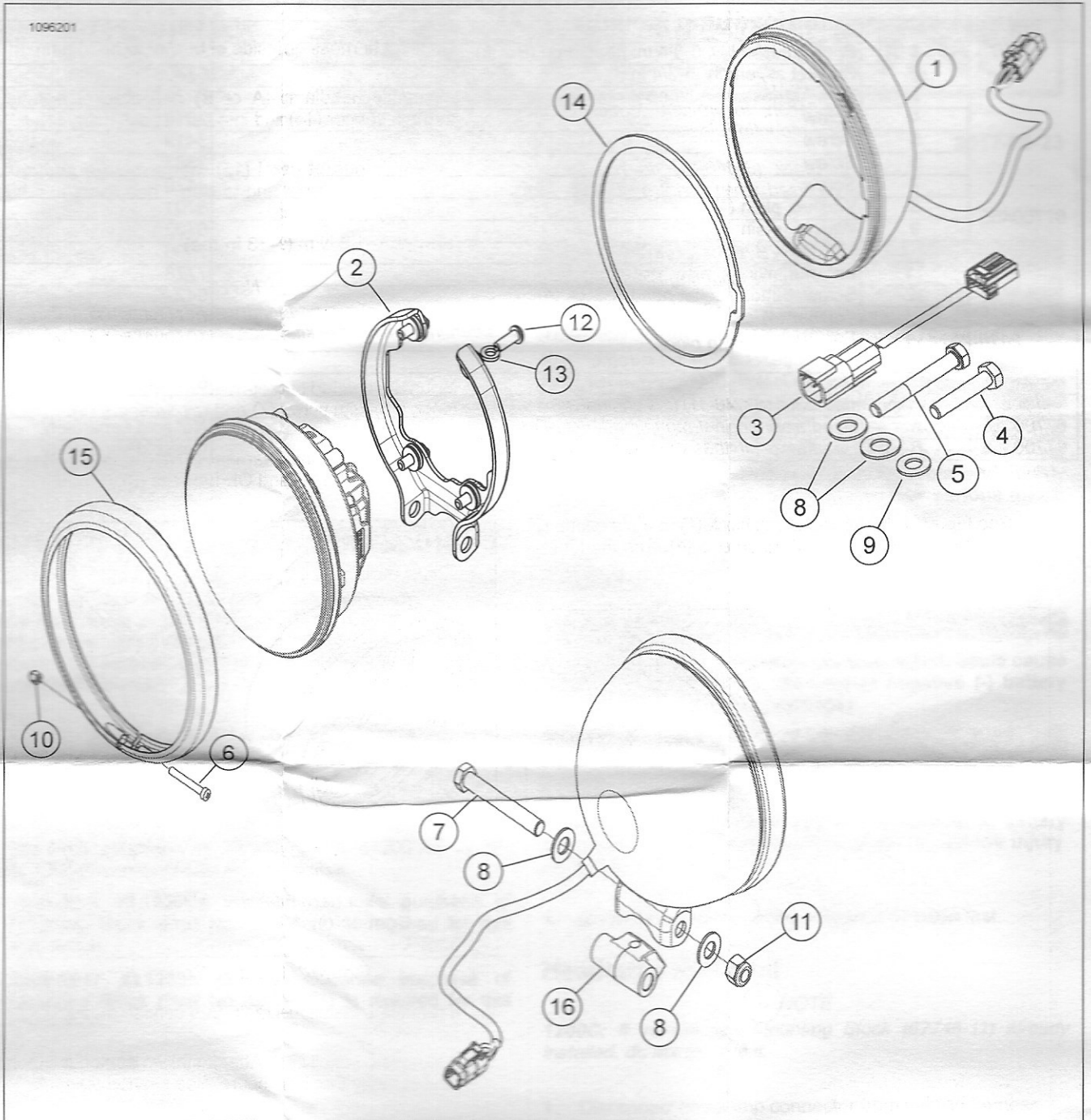

Figure 3. Service Parts: Headlamp Shell

Table 1. Service Parts

Kit	Item	Description (Qty)	Part No.
67700455	1	Bucket assembly, 5-3/4 in. headlamp (Black)	67700380
	2	Bracket assembly, 5-3/4 in.	67700483
	3	Wire harness, headlamp	69201838
	4	Screw	2818
	5	Screw	3419
	6	Screw	3383
	7	Screw	4420
	8	Washer, plain (4)	6701
	9	Washer, plain	6702
	10	Hexnut	7606
	11	Locknut, nylon insert	7778
	12	Screw, button socket head, TORX (4)	942
	13	Washer (4)	67700455_02
	14	Spacer, headlight	12400155
	15	Bucket bezel, 5-3/4 in., chrome	67700375
	16	Mount block, 5-3/4 in.	67700377
Items mentioned but not included.			
67700355	A	Headlamp	Not sold separately
67700356	B	Headlamp	Not sold separately