



INSTRUCTIONS

-J03602

REV. 2007-05-10

SCREAMIN' EAGLE RACE CLUTCH

GENERAL

Kit Number

37970-03A

Models

1999 through 2006 Twin Cam models (does not fit '06 Dyna's or '07 Twin Cams) motorcycles and '90 - '99 1340 Evolution model motorcycles (does fit models with Hydraulic clutch)

Additional Parts Required

For 1994-1997 Evolution models: Clutch shell (Part Number 37707-98) and Rod Adjuster Screw (Part Number 37090-98) must also be installed.

For 1990-1993 Evolution models: Clutch shell (Part Number 37707-98), Rod Adjuster Screw (Part Number 37090-98) and Starter (Part Number 31553-94) or modification to starter extension shaft to fit Pinion Gear (Part Number 31342-93), Bushings (Part Number 33445-94A) and (Part Number 33446-94) sleeved to fit in primary or Primary Housing Assembly (Part Number 60663-95) must also be installed.

WARNING

The rider's safety depends upon the correct installation of this kit. Use the appropriate service manual procedures. If the procedure is not within your capabilities or you do not have the correct tools, have a Harley-Davidson dealer perform the installation. Improper installation of this kit could result in death or serious injury. (00333a)

NOTE

This instruction sheet references Service Manual information. A Service Manual for your model motorcycle is required for this installation and is available from a Harley-Davidson Dealer.

Kit Contents

Table 1. Kit Contents

Description (Quantity)	Part Number
Locknut (6)	7682
Center, clutch assembly	37957-98
Set, friction and spacer discs	37980-03
Studs (6)	37959-98
Spring caps (6)	37954-98
Clutch springs (6)	45884-98
Pressure plate	37953-98
SE derby cover gasket	25477-04

INSTALLATION

NOTE

Refer to applicable Harley-Davidson Service Manual for installation of clutch, but note the following exceptions:

NOTICE

Do not reinstall the damper spring and/or damper spring seat with this kit. Doing so will effect the stacked height of the clutch discs. Failure to comply could result in premature clutch failure and possible engine damage. (00459b)

NOTE

The derby cover gasket must be replaced each time the derby cover is removed.

1. Use derby cover gasket supplied in this kit.
2. See Figure 1. The clutch assembly replaces the original equipment single diaphragm spring with six coil springs. The coil springs allow for easy adjustment of clutch force. The total clutch force is adjustable from zero to 500 pounds. The force is increased or decreased by turning the locknuts (1) which retain the coil springs to the pressure plate.

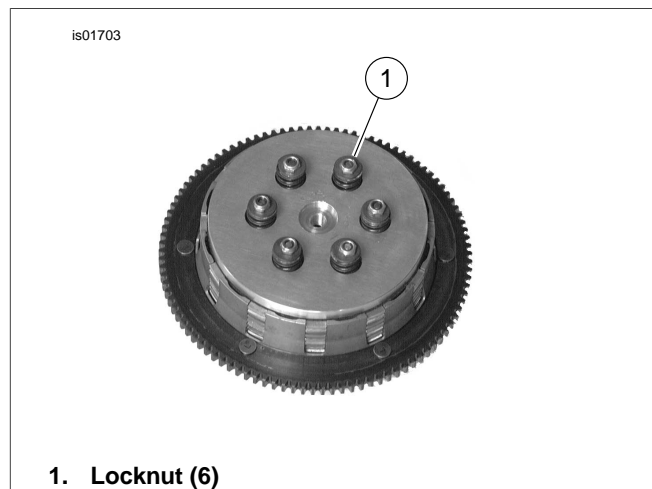

1. Locknut (6)

Figure 1. Clutch Components Installed

3. Based on the engine's torque output at the crankshaft, determine the total spring force and spring height required (See Spring Force Calculations Table.).

is01704

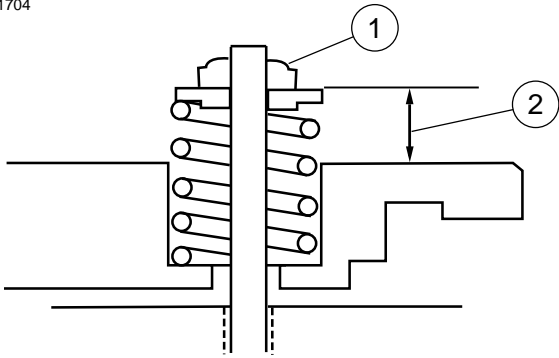

- 1. Locknut
- 2. Clutch spring height

Figure 2. Measuring Spring Height

- 4. See Figure 2. Tighten locknuts (1) in a cross-wise bolt pattern to the spring height (2) as determined in step 2. In all cases, the adjustment height must be equal on all six coil springs.
- 5. The clutch spring height (2) and cable free play must be checked and adjusted periodically to compensate for friction plate wear. These adjustments are especially important during the friction plates break-in period. Also, look for signs of clutch slippage and increase the total spring force accordingly.

NOTE

On 1996 and earlier 1340 models (with 24 tooth engine sprockets) the total spring force must be increased from the chart below by 4%.

SPRING FORCE CALCULATIONS TABLE

Table 2. Models

Engine Torque @ Crank, ft-lbs	Total Spring Force (lbf)	Spring Height (inches)
50	154	0.366
60	185	0.356
70	215	0.345
80	246	0.334
90	277	0.324
100	309	0.313
110	340	0.302
120	371	0.291
130	402	0.280
140	433	0.269
150	464	0.259
160	495	0.248