



# INSTRUCTIONS

-J03495

REV. 2006-11-01

## VENTED FAIRING LOWERS KIT

### GENERAL

#### Kit Number

58854-xx

#### Models

For model fitment information, please see the P&A Retail Catalog or the Parts and Accessories section of [www.harley-davidson.com](http://www.harley-davidson.com) (English only).

#### WARNING

**Federal Motor Vehicle Safety Standard (FMVSS) 108 requires motorcycles to be equipped with rear and side reflectors. Be sure rear and side reflectors are properly mounted. Poor visibility of rider to other motorists can result in death or serious injury. (00336b)**

#### NOTE

*A Service Manual for your model motorcycle is available from any Harley-Davidson Dealer.*

#### Kit Contents

See Figure 1 and Table 1.

#### WARNING

**The rider's safety depends upon the correct installation of this kit. If the procedure is not within your capabilities or you do not have the correct tools, have a Harley-Davidson dealer perform the installation. Improper installation of this kit could result in death or serious injury. (00308a)**

### INSTALLATION

1. See Figure 1. From the kit, obtain the left side fairing lower (1), left side fairing lower cap (2), two flange locking nuts (3) and two stud clips (4). Place fairing lower cap in front of the left side engine guard and left side fairing lower behind engine fairing guard. With both pieces in place around engine guard, install the two flange locking nuts onto the studs clips and hand tighten. Repeat procedure for right side fairing lower.
2. Secure bottom of fairing lower to lower engine guard with round clamp (5) from hardware kit. Position clamp around engine guard with tabs toward rear of vehicle and flat side of clamp against fairing lower and with the rubber washer (6) between clamp and engine guard. Place Torx pan screw (7) through fairing lower, rubber washer and clamp. Secure assembly with flanged locknut (8). Repeat for right side fairing lower. Tighten to 144 **in-lbs** (16.3 Nm).
3. Tighten all left and right side upper flange locking nuts (3) to 72 **in-lbs** (8.1 Nm).
4. Install left side door assembly glovebox (9) to fairing lower using the attachment cord (10). Insert glovebox door into fairing lower. Repeat for right side fairing lower.

#### NOTE

*Do not press reflector firmly into place until you have it positioned in desired location. The adhesive is very strong and once it comes in contact with a surface, it will be difficult to remove without damaging the reflector.*

5. Peel adhesive strip off back of reflector from kit. Position reflector on side of front fender above chrome side trim strip and approximately 4 inches rearward from front of fender. Press reflector securely into place. Repeat for opposite side reflector.

# SERVICE PARTS

is02371

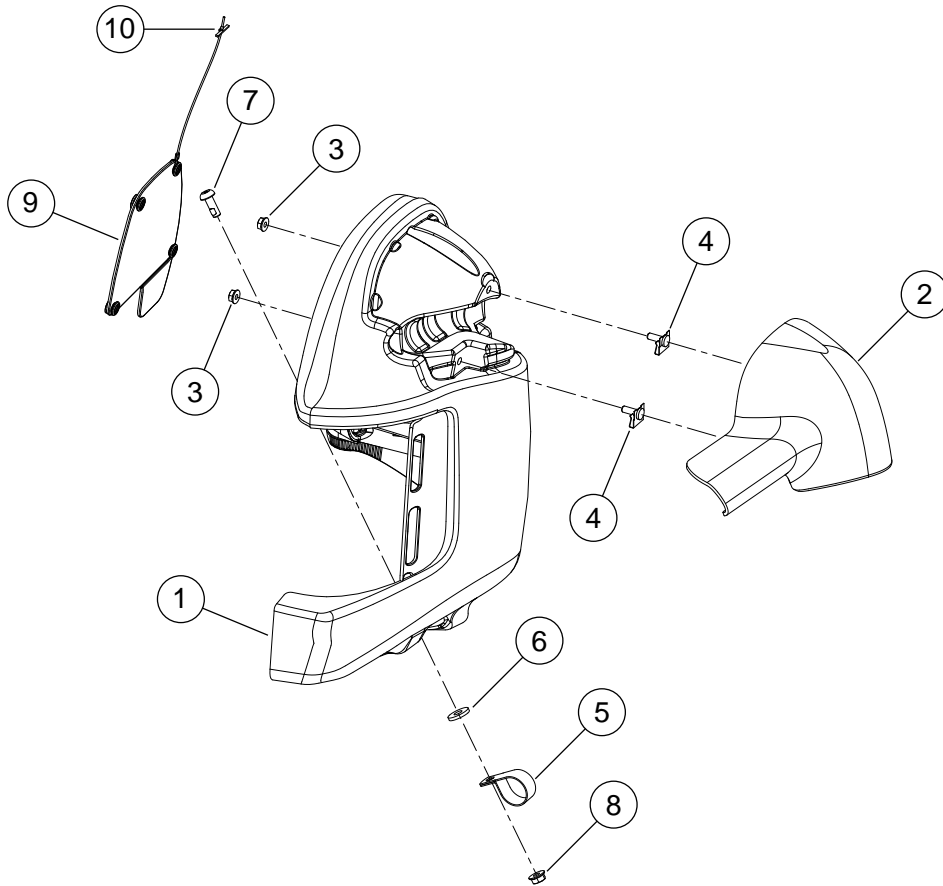

**Figure 1. Service Parts: Vented Fairing Lower Kit**

**Table 1. Service Parts Table**

Item	Description (Quantity)	Part Number
1	Fairing lowers, left (left shown)	58851-xx
	Fairing lowers, right	58852-xx
2	Fairing lowers cap, left (left shown)	58491-xx
	Fairing lowers cap, right	58492-xx
3	Flange locking nut (4)	7716
4	Stud clip (4)	8175
5	Clamp (2)	27048-84
6	Rubber washer (2)	7415A
7	Screw, pan, H-DTorx w/lock (2)	3655A
8	Flange nut (2)	7576
9	Left side door assembly glovebox	58681-05
10	Glovebox attachment cord	Not sold
11	Right side door assembly glovebox (not shown)	58679-05
12	Front fender reflectors (2) (not shown)	59256-84A